

Compact outdoor  
detector

fit series

NO.59-1646-0 091201

## INSTALLATION INSTRUCTIONS



N219

FTN-R	Battery operated model with 2 PIRs
FTN-RAM	FTN-R with anti-masking

- Long battery life
- Easy wiring by a connector
- Multi fixing transmitter box
- Compact design
- 190° adjustable bracket
- Intelligent AND logic
- Digital anti-masking (RAM model)
- Wall tamper (option)

## CONTENTS

1 INTRODUCTION	
1-1 BEFORE INSTALLATION.....	2
1-2 PARTS IDENTIFICATION.....	3
1-3 DETECTION AREA.....	4
2 INSTALLATION	
2-1 WIRING DIAGRAM.....	4
2-2 TRANSMITTER PREPARATION.....	5
2-3 BEFORE WALL MOUNTING.....	6
2-4 STACKING METHOD.....	7
2-5 SIDE-BY-SIDE AND TOP-TO-BOTTOM METHOD .....	11
3 WALK TEST	
3-1 WALK TEST.....	13
4 DIP SWITCH SETTING	
4-1 WALK TEST MODE.....	14
4-2 BATTERY SAVING TIMER.....	14
4-3 ALARM & TROUBLE OUTPUT .....	14
4-4 LED.....	15
4-5 PIR SENSITIVITY.....	15
4-6 ANTI-MASKING.....	15
5 OTHERS	
5-1 WALL TAMPER (OPTION) CONNECTION.....	16
5-2 LED LIGHT PATTERN.....	16
6 BATTERY	
6-1 HOW TO REPLACE BATTERY .....	17
6-2 BATTERY LIFE .....	18
7 SPECIFICATIONS	
7-1 SPECIFICATIONS.....	19
7-2 DIMENSIONS.....	20

# 1 INTRODUCTION

## 1-1 BEFORE INSTALLATION

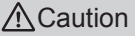
 <b>Warning</b>	Failure to follow the instructions provided with this indication and improper handling may cause death or serious injury.
 <b>Caution</b>	Failure to follow the instructions provided with this indication and improper handling may cause injury and/or property damage.

The check  mark indicates recommendation.

The nix  sign indicates prohibition.

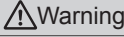
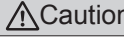
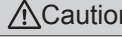
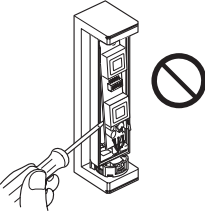
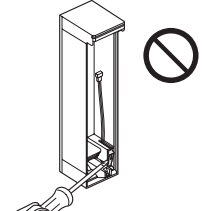
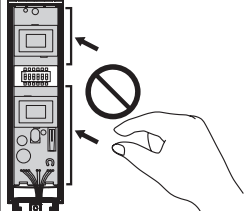
 <b>Warning</b>	 <b>Caution</b>	 <b>Caution</b>
<p>Do not remove the PCB.</p> 	<p>Do not remove the separate box tamper.</p> 	<p>Do not touch the PCB except for the DIP switch.</p> 

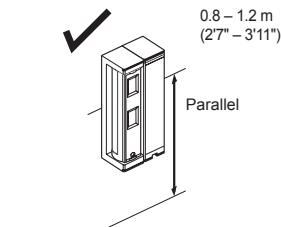
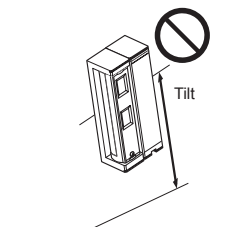
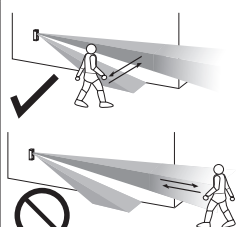
<p>Mounting height.</p>  <p>0.8 – 1.2 m (27" – 3'11")</p> <p>Parallel</p>	<p>Keep the detector parallel to the ground.</p>  <p>Tilt</p>	<p>Consider the direction a person is approaching from, as well as the detection area.</p> 
---	---	--

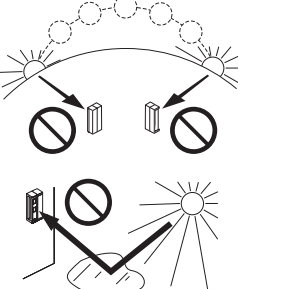
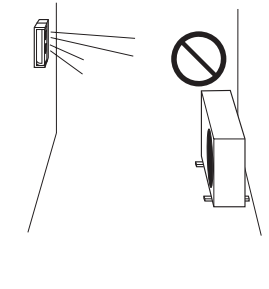
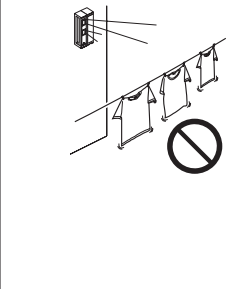
<p>Install the detector in a place where it is free from false alarm factors. For example:</p>		
<p>• Sunlight and reflection</p> 	<p>• Heat source</p> 	<p>• Objects moving in the wind</p> 

## 1-2 PARTS IDENTIFICATION

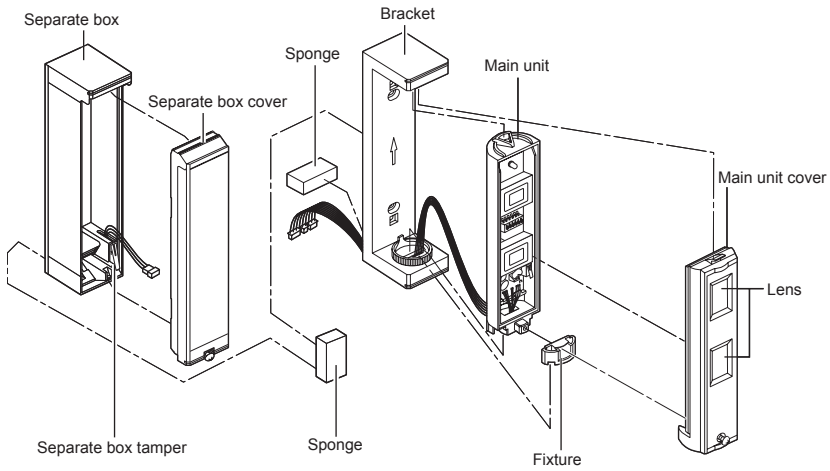

Connector for POWER and ALARM







Connector for TROUBLE



Sponge for transmitter



### Screw kit

For joint	For wall mounting
Screw (M3 × 10 mm)	Screw (3 × 20 mm)
 Plate nut 	 

### Note>>

- Transmitter and battery are not included.

### -Optional accessories

Wall tamper (WRS-03)



## 1-3 DETECTION AREA

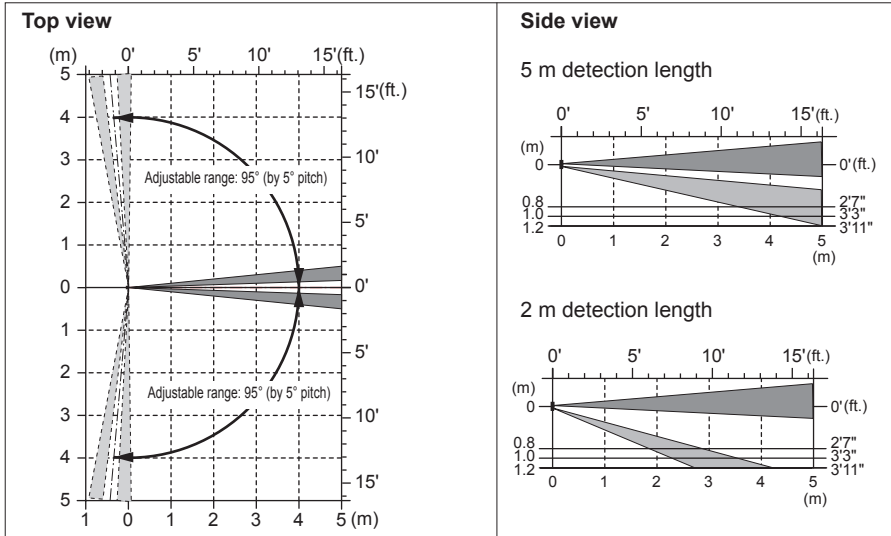

## 2 INSTALLATION

### 2-1 WIRING DIAGRAM

#### -Overall wiring diagram

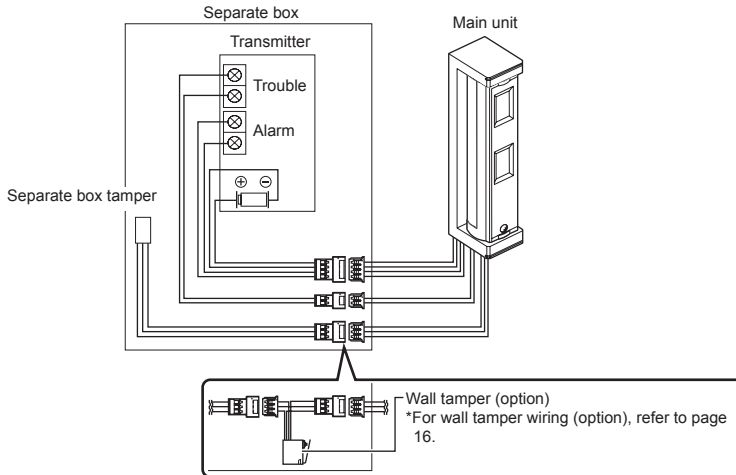

#### Notes>>

- The battery in the transmitter is shared with the detector.
- Connection for TROUBLE is used when monitoring for Tamper and Anti Mask.

## 2-2 TRANSMITTER PREPARATION

The transmitter used should have the internal dimensions of H 130 × W 30 × D 35 mm.  
(H 5.12" × W 1.18" × D 1.38")

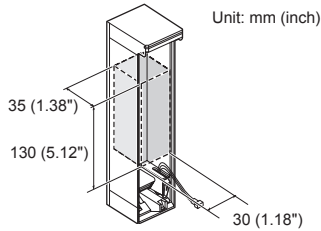

**Connectors to be used**

Connector for POWER and ALARM

Connector for TROUBLE

How to position a battery

Red

Black

### -When monitoring ALARM and TROUBLE using the transmitter with 1 external input

External input is N.C.

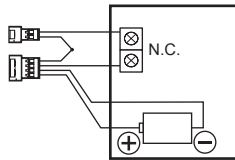

... DIP switch 3: OFF (N.C.)  
3

External input is N.O.

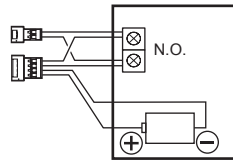

... DIP switch 3: ON (N.O.)  
3

### -To monitor only the ALARM using a transmitter with 1 external input

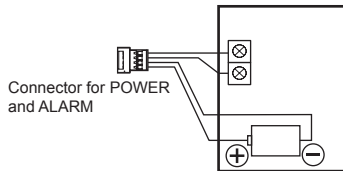

### -To monitor the ALARM and TROUBLE using a transmitter with 2 external inputs

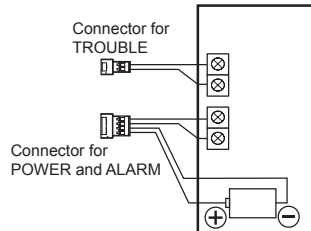

## 2-3 BEFORE WALL MOUNTING

1 Open the main unit cover.

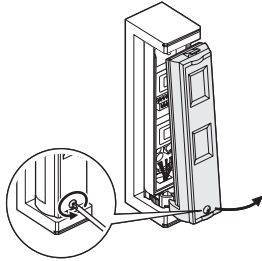

2 Remove the fixture.

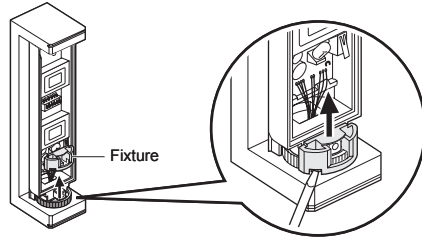

3 Hold the top of the bracket and remove the main unit.

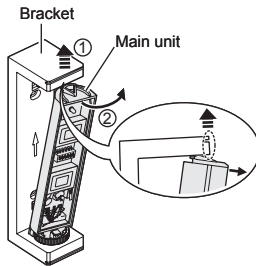

4 Open the separate box.

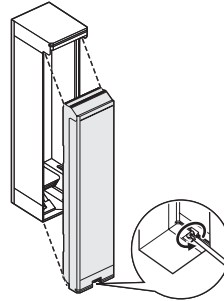

### Note>>

- Be sure to keep connectors installed through the bottom part of bracket after main unit is removed.

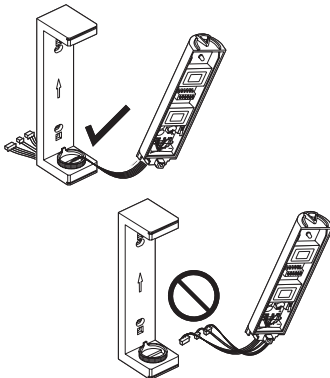

### Note>>

- Do not remove the separate box tamper.

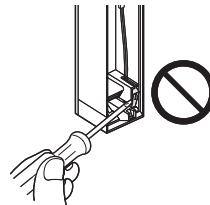

## 5 Select the mounting method.

Stacking method  
(Page 7)

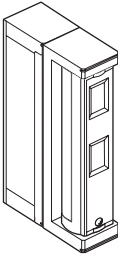

Side-by-side method  
(Page 11)

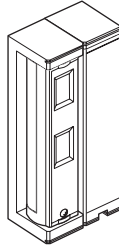

Top-to-bottom method  
(Page 11)

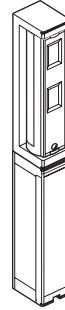

### Note>>

- Be sure to mount the main unit on the top.

## 2-4 STACKING METHOD

For the side-by-side method and the top-to-bottom method, refer to page 11.

### 6 Open the knockout.

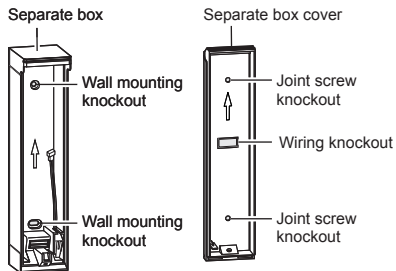

### 7 Pull the connectors through the wiring knockout.

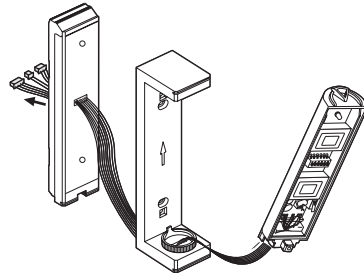

**8 Attach the separate box cover and the bracket.**

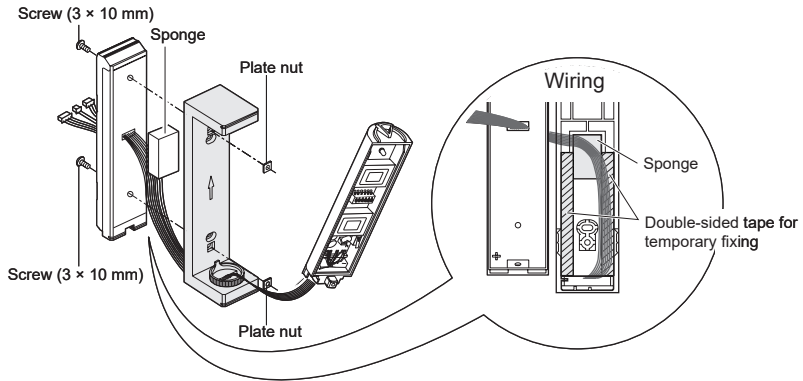

**Notes>>**

- Be careful not to attach separate box cover upside down.
- Be careful not to pinch wires.

**9 Hold the top part of the bracket and mount the main unit.**

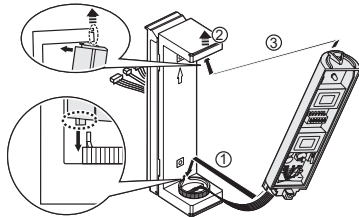

**10 Mount the separate box on the wall.**

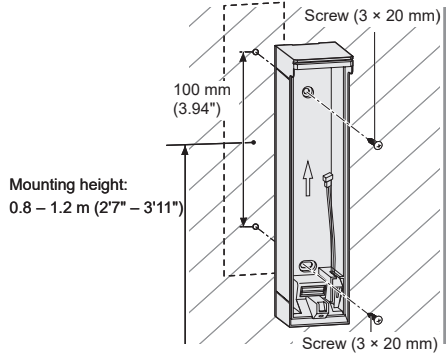



## 11 Connect the connectors.

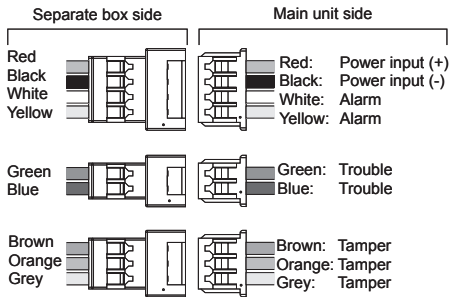

### Notes>>

- The tamper output is not exclusive. The Anti-masking and Tamper circuits share the Trouble output.
- For the wall tamper wiring connection (option), refer to page 16.
- To detect cutoff of tamper input wires (3 wire line) as shown in the illustration, cut the orange jumper wire provided for purpose of detection. In this case, be sure to use the connector of the separate box tamper. Otherwise, the trouble output will remain on.



## 12 Install the transmitter and attach the separate box cover.

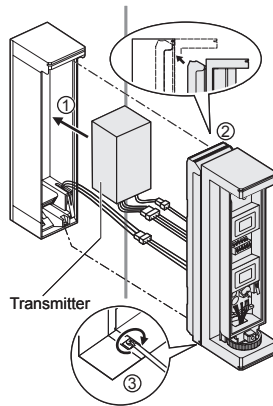

### Note>>

- Please use the sponge for transmitter when needed.

## 13 Determine the horizontal detection angle and attach the fixture.

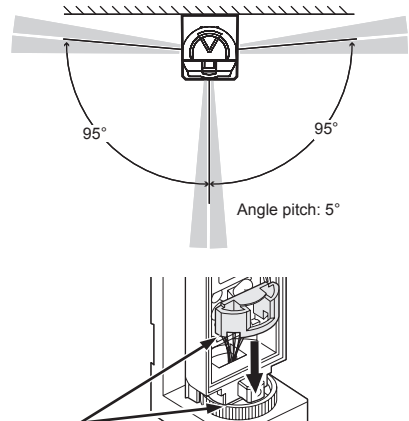

### Note>>

- Check that the fixture and bracket engage correctly.



### Note>>

- To make adjustments, remove the fixture.

**14 Determine the detection length. (2 m or 5 m)**

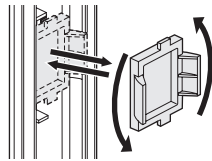
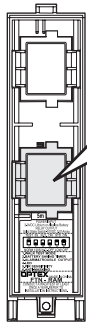

If 2 m is required, rotate the lower lens 180 degrees.

**Note>>**

- Do not remove the upper lens.

**5 m detection length  
(Factory default)**

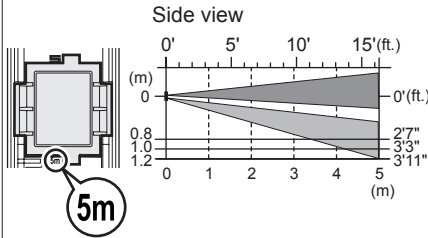

**2 m detection length**

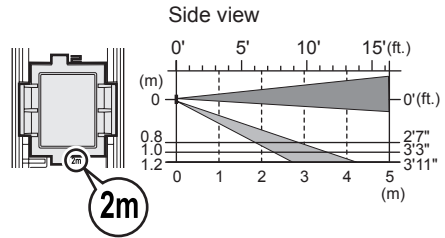

**15 Attach the main unit cover.**

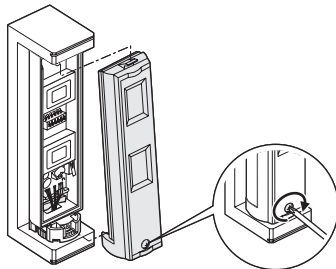

**Note>>**

- To prepare for walk test, check that DIP switch 1 (WALK TEST MODE) is set to "ON (TEST)" before attaching main unit cover.

**16 Perform walk test.  
For details, refer to page 13.**

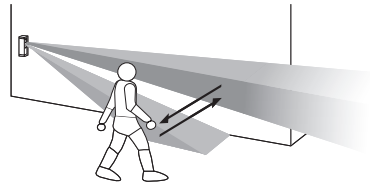

**17 After walk test is complete, set DIP switch 1 (WALK TEST MODE) from "ON" to "OFF".**

**Note>>**

- The battery life will be shortened unless the DIP switch 1 is set to "OFF".

## 2-5 SIDE-BY-SIDE AND TOP-TO-BOTTOM METHOD

For the stacking method, refer to page 7.

### 6 Open the knockout.

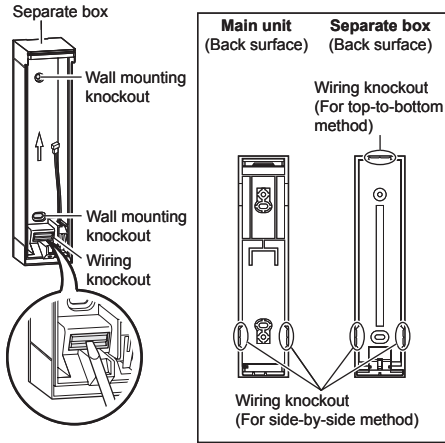

### 7 Pull the wire connectors through wiring knockout.

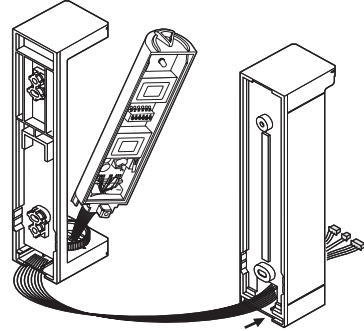

### 8 Mount the bracket and the separate box to the wall.

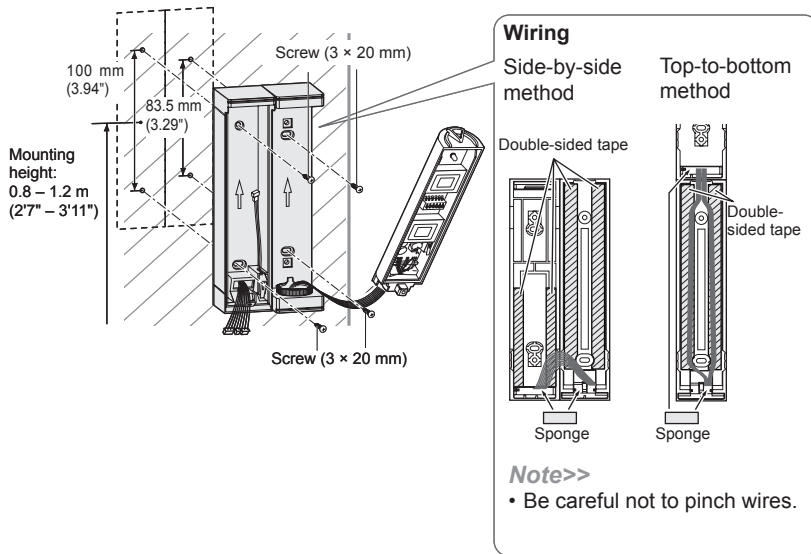

**9 Hold the top part of the bracket and mount the main unit.**

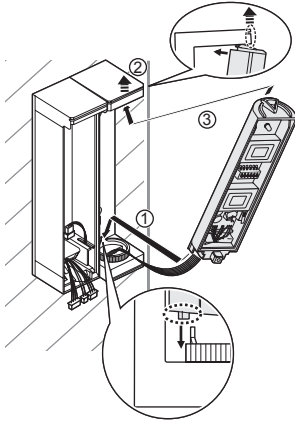

**10 Connect the connectors.**

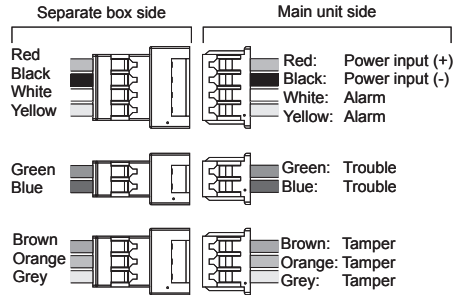

**Notes>>**

- The tamper output is not exclusive. The Anti-masking and Tamper circuits share the Trouble output.
- For the wall tamper wiring connection (option), refer to page 16.
- To detect cutoff tamper input wires (3 wire line) as shown in the illustration, cut the orange jumper wire provided for purpose of detection. In this case, be sure to use the connector of the separate box tamper. Otherwise, the trouble output will remain on.

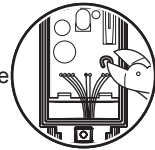

**11 Install the transmitter and attach the separate box cover.**

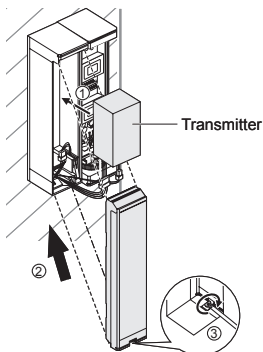

**12 For the subsequent procedure, refer to steps 13 to 17 (page 9 to 10).**

### 3 WALK TEST

#### 3-1 WALK TEST

- 1 Set the DIP switch 1 (WALK TEST MODE) to “ON (TEST)”.

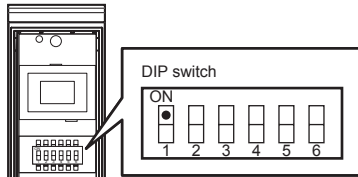

**Note>>**

- The switch is set to “ON (TEST)” by factory default.

- 2 Check that LED lights for 2 seconds when the intended object is detected.

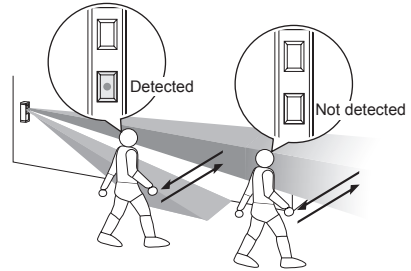

- 3 Set the DIP switch 1 (WALK TEST MODE) to “OFF (NORM)”.

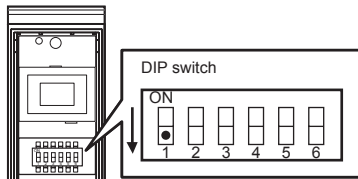

**Notes>>**

- The battery life will be shortened unless the DIP switch 1 is set to “OFF”.
- To use the LED in normal operating condition, set the DIP switch 4 to “ON”.

## 4 DIP SWITCH SETTING

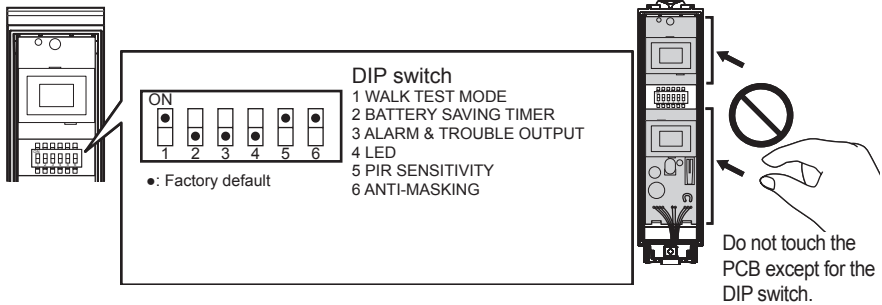

### 4-1 WALK TEST MODE

DIP switch 1

FTN-R  
FTN-RAM

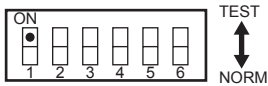

Position	Function
TEST (Factory default)	<ul style="list-style-type: none"> <li>• The LED lights irrespective of the DIP switch 4 (LED) setting.</li> <li>• The DIP switch 2 (BATTERY SAVING TIMER) setting is inactive.</li> </ul>
NORM	<ul style="list-style-type: none"> <li>• The LED lights depending on the DIP switch 4 (LED) setting.</li> <li>• The DIP switch 2 (BATTERY SAVING TIMER) setting is active.</li> </ul>

### 4-2 BATTERY SAVING TIMER

DIP switch 2

FTN-R  
FTN-RAM

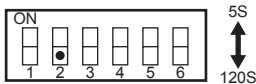

Position	Function
5S	5 sec.
120S (Factory default)	120 sec.

**Note>>**

- The detector will not generate alarms at intervals shorter than the specified time.

### 4-3 ALARM & TROUBLE OUTPUT

DIP switch 3

FTN-R  
FTN-RAM

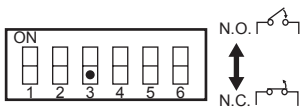

Position	Function
N.O.	N.O. output
N.C. (Factory default)	N.C. output

**4-4 LED** DIP switch 4 FTN-R  
FTN-RAM

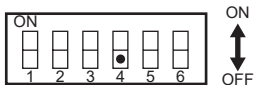

Position	Function
ON	LED ON
OFF (Factory default)	LED OFF <i>Note&gt;&gt;</i> • If the LED lights, check the DIP switch 1 (WALK TEST MODE) setting.

**4-5 PIR SENSITIVITY** DIP switch 5 FTN-R  
FTN-RAM

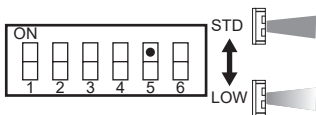

Position	Function
STD (Factory default)	Normal sensitivity
LOW	Low sensitivity

**4-6 ANTI-MASKING** DIP switch 6 FTN-R  
FTN-RAM

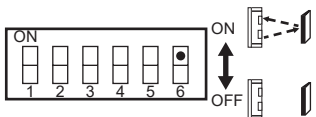

Position	Function
ON (Factory default)	ANTI-MASKING ON
OFF	ANTI-MASKING OFF

**-ANTI-MASKING function**

When masking condition continues more than 3 minutes, TROUBLE will be generated. TROUBLE is generated after 20 seconds under the anti-masking test mode.

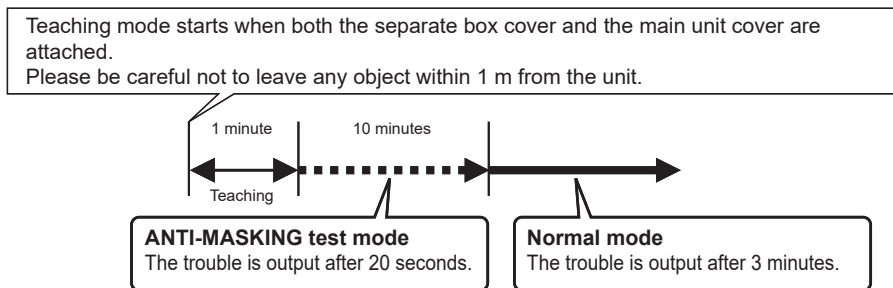

## 5 OTHERS

### 5-1 WALL TAMPER (OPTION) CONNECTION

Connect the tamper connector as shown below when connecting a wall tamper (option).

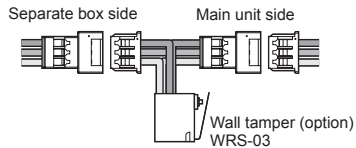

#### Mounting position

Stacking method

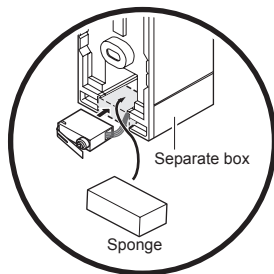

Side-by-side method and top-to-bottom method

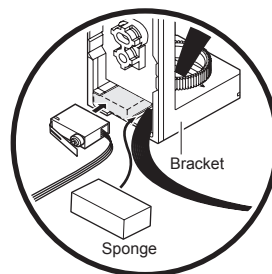

### 5-2 LED LIGHT PATTERN

The following explains the LED light pattern.











Blink



Light



OFF

Detector condition	LED indicator
Warm-up  <i>Note&gt;&gt;</i> • The LED blinks even if the DIP switch 4 (LED) is set to "OFF".	 →  Blinks for approx. 120 seconds.
Alarm	 →  Lights for 2 seconds.
Masking detection (FTN-RAM only)	    Blinks 3 times and then repeats.



## 6 BATTERY

The detector shares the battery with the transmitter. Check that the 2.5 to 10.0 V power battery is used for the transmitter.

### 6-1 HOW TO REPLACE BATTERY

- 1 Open the separate box, and disconnect the transmitter connector. (It is not necessary for the main unit to be opened.)

Stacking method

Side-by-side method and top-to-bottom method

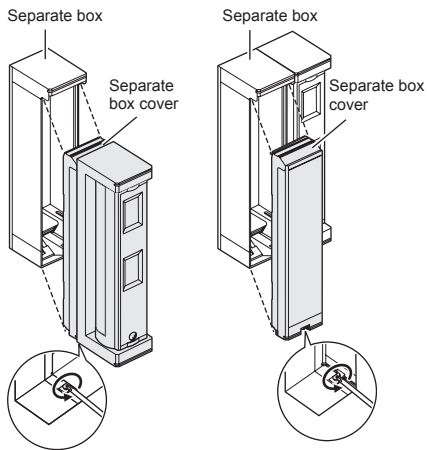

- 2 Replace the battery.

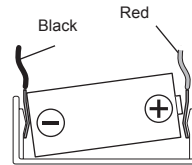

- 3 Connect the connector, and close the separate box.

#### Note>>

- Check that the warm-up period is started.

## 6-2 BATTERY LIFE

The values indicated are only for reference on condition that the detector is exceptionally operated by the sole battery.

It is impossible to indicate the battery life under the normal operation as the battery in the transmitter is shared with the detector.

	Interval 120 sec	Interval 5 sec
CR123A (3 V, 1300 mAh)	Approx. 6 years	Approx. 5 years
CR2 (3 V, 750 mAh)	Approx. 4 years	Approx. 3 years
1/2AA (3.6 V, 1000 mAh)	Approx. 5 years	Approx. 4 years

### **Note>>**

- Data shown here is when the LED is off, AM is on. Battery life becomes shorter when the LED is on.

## 7 SPECIFICATIONS

### 7-1 SPECIFICATIONS

Model	FTN-R	FTN-RAM
Detection method	Passive infrared	
PIR coverage	5 × 1 m (16'5" × 3'3")	
Detection length limit	2 m, 5 m (6'7", 16'5")	
Detectable speed	0.3 – 1.5 m/s (1' – 4'11"/s)	
Sensitivity	2.0°C (at 0.6 m/s) (3.6°F (at 2'/s))	
Operation voltage	2.5 – 10 V DC	
Power input	3 – 9 V DC (Lithium or Alkali Battery)	
Current draw	9 µA (at stand-by)/3 mA (max.) (at 3 V DC)	10 µA (at stand-by)/3 mA (max.) (at 3 V DC)
Alarm period	2.0 ±1.0 sec.	
Warm-up period	Approx. 120 sec. (LED blinks)	
Alarm output	N.C./N.O. Selectable-Solid State Switch 10 V DC 0.01 A (max.)	
Trouble output	N.C./N.O. Selectable-Solid State Switch 10 V DC 0.01 A (max.)	
LED indicator	Enable: During DIP switch 1 (WALK TEST MODE) or DIP switch 4 (LED) ON Disable: During normal operation Light/Blink: Warm-up, alarm, masking detection	
RF Interference	No alarm 10 V/m	
Operation temperature	-20 – +60°C (-4 – +140°F)	
Environment humidity	95% max.	
Weatherproof	IP55	
Mounting	Wall (Outdoor, Indoor)	
Mounting height	0.8 – 1.2 m (2'7" – 3'11")	
Weight	190 g (6.7 oz.)	
Accessories	Connector for POWER and ALARM, connector for TROUBLE, plate nut × 2, screw (M3 × 10 mm) × 2, screw (3 × 20 mm) × 4, sponge for transmitter	

\*Specifications and design are subject to change without prior notice.

## 7-2 DIMENSIONS

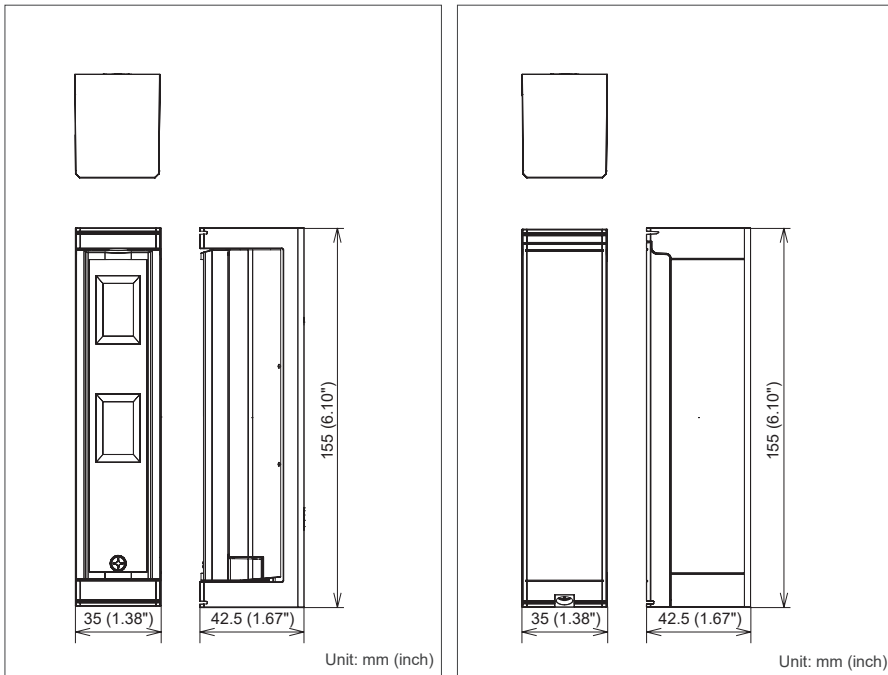

### Note>>

- These units are designed to detect an intruder and activate an alarm control panel. Being only a part of a complete system, we cannot accept responsibility for any damages or other consequences resulting from an intrusion. These products confirm to the EMC Directive 2004/108/EC.



### OPTEX CO., LTD. (JAPAN)

(ISO 9001 Certified)  
(ISO 14001 Certified)

5-8-12 Ogoto Otsu  
Shiga 520-0101  
JAPAN

TEL:+81-77-579-8670  
FAX:+81-77-579-8190

URL:<http://www.optex.co.jp/el>

### OPTEX INCORPORATED (USA)

TEL:+1-909-993-5770  
Tech:(800)966-7839  
URL:<http://www.optexamerica.com/>

### OPTEX (EUROPE) LTD. (UK)

TEL:+44-1628-631000  
URL:<http://www.optexeurope.com/>

### OPTEX SECURITY SAS (FRANCE)

TEL:+33-437-55-50-50  
URL:<http://www.optex-security.com/>

### OPTEX SECURITY Sp. z o. o. (POLAND)

TEL:+48-22-598-06-55  
URL:<http://www.optex.com.pl/>

### OPTEX KOREA CO., LTD. (KOREA)

TEL:+82-2-719-5971  
URL:<http://www.optexkorea.com/>

### OPTEX (DONGGUAN) CO., LTD.

SHENZHEN OFFICE (CHINA)  
TEL:+86-755-33302950  
URL:<http://www.optexchina.com/>